

HABE LAVABO QUADRATO

MATERIALE: KHROMALITE

PILETTA: NON INCLUSA

PESO NETTO: 4 Kg

PESO LORDO: 6 Kg

DIMENSIONE IMBALLO: 50x50xh20

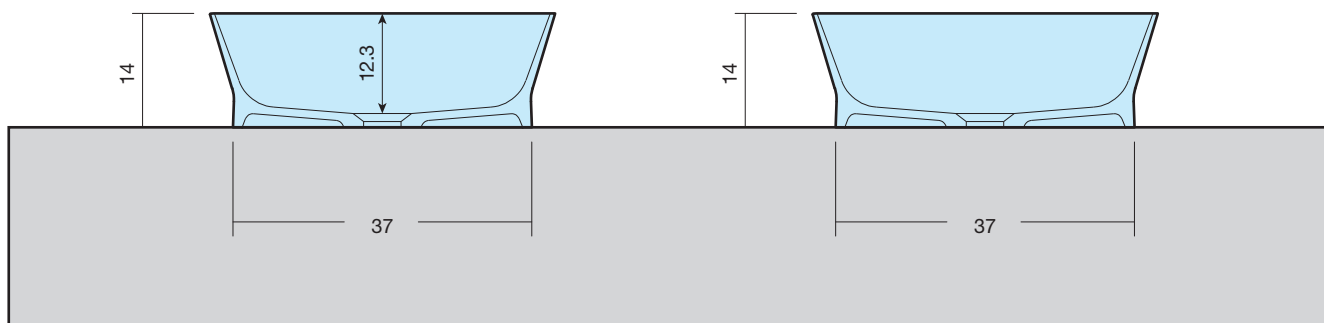
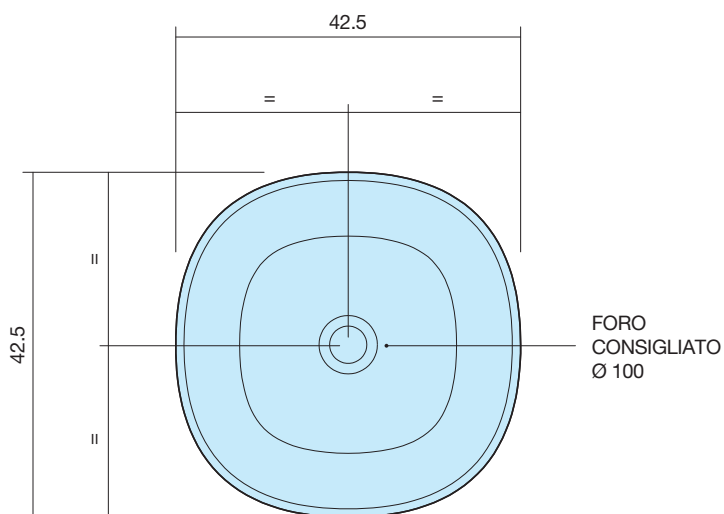

DISENIA

Disenia srl
via A. Carpenè, 21
33070
Brugnera (PN)
Italy

INFO
Tel. +39 0434 1822603
Fax +39 0434 020013
www.disenia.it
e-mail: info@disenia.it

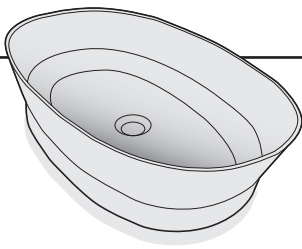

HABE LAVABO RETTANGOLARE

MATERIALE: KHROMALITE

PILETTA: NON INCLUSA

PESO NETTO: 6 Kg

PESO LORDO: 8 Kg

DIMENSIONE IMBALLO: 48x63xh20

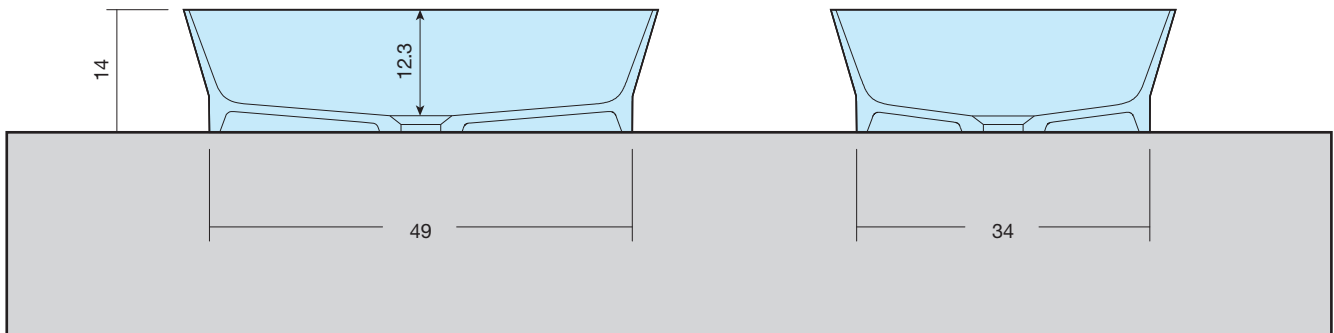
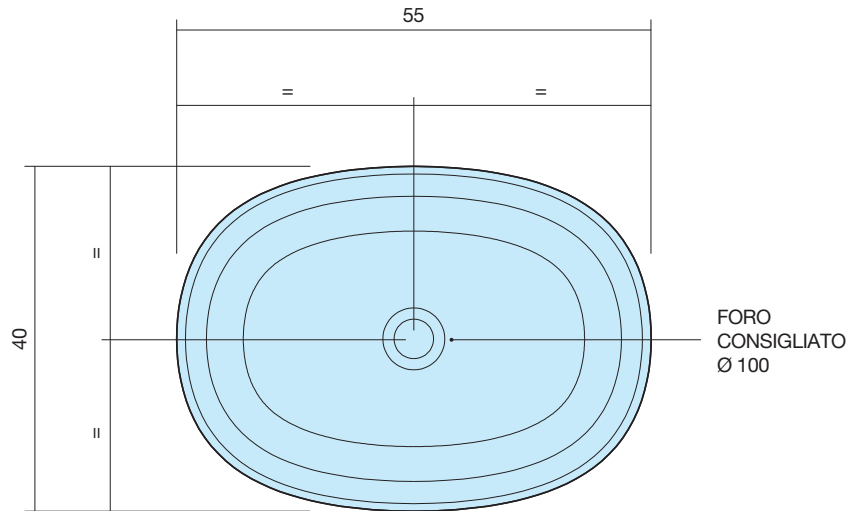

DISENIA

Disenia srl
via A. Carpenè, 21
33070
Brugnera (PN)
Italy

INFO
Tel. +39 0434 1822603
Fax +39 0434 020013
www.disenia.it
e-mail: info@disenia.it

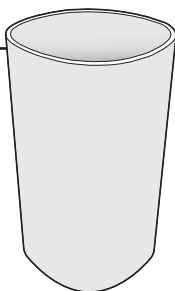

HABE LAVABO FREESTANDING

MATERIALE: KHROMALITE

PILETTA: NON INCLUSA

PESO NETTO: 29 Kg

PESO LORDO: 34 Kg

DIMENSIONE IMBALLO: 52x52xh105

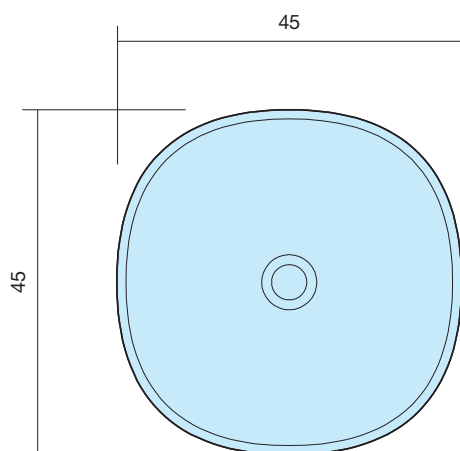

CON SCARICO A PAVIMENTO,
SI CONSIGLIA L'UTILIZZO
DEL SIFONE DEDICATO

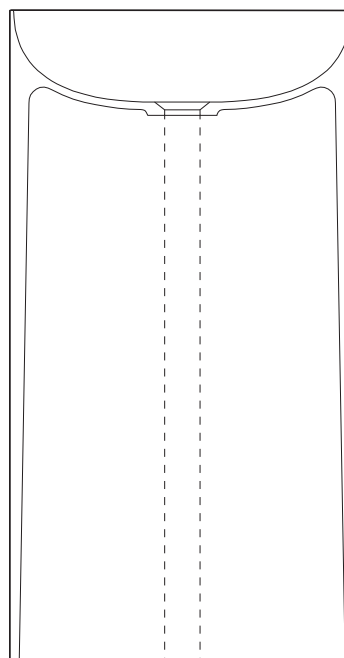
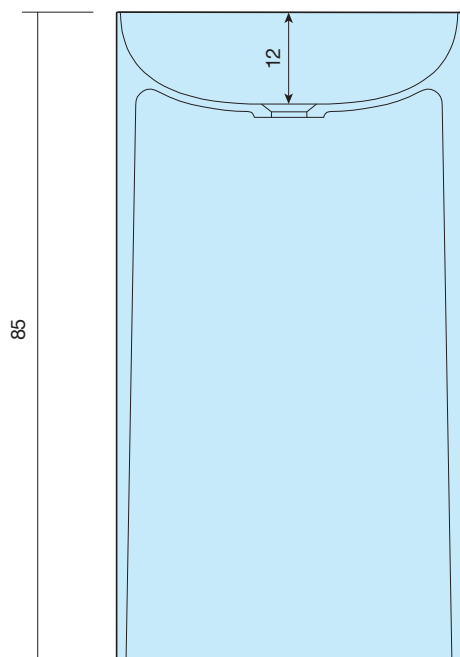

DISENIA

Disenia srl
via A. Carpenè, 21
33070
Brugnera (PN)
Italy

INFO
Tel. +39 0434 1822603
Fax +39 0434 020013
www.disenia.it
e-mail: info@disenia.it